

Full Hospital Bed Assembly

This procedure works best with two people

Most hospital beds assemble in the same manner and can be done in a matter of 5-10 minutes. Both fully-electric and semi-electric hospital beds assemble basically the same way. There are slight variations depending on model/year. Example, newer full-electric hospital beds may have one single motor instead of three separate motors. Semi-electric may only have one motor instead of two.

Spring Section (if not assembled previously)

The foot-spring (with motor assembly) and head-spring sections latch together in the center at a center pivot point. This is best achieved by setting these sections on their side approximately 90° from each other as in the first figure below. Slide the open ends of the center mounting latch over both of the rivet ends to connect, as seen in the second set of photos.

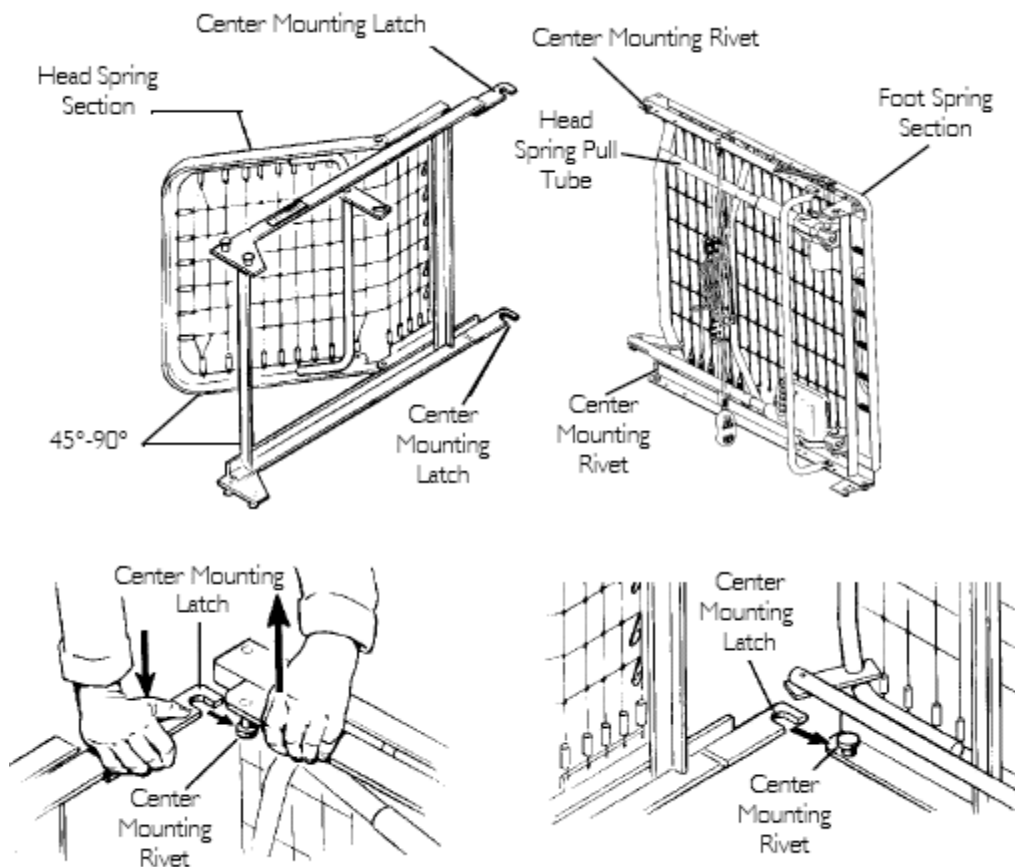

After the 2 halves are attached to each other you can straighten out the bed base, keeping it on its side.

Take a look at the spring section and you will see loose spring-links that connect the two sides together to give one complete surface for the mattress. Lift the head spring away from the bed frame to give slack to the links. Connect the spring links together with the links provided. (See photo on the top of the next page)

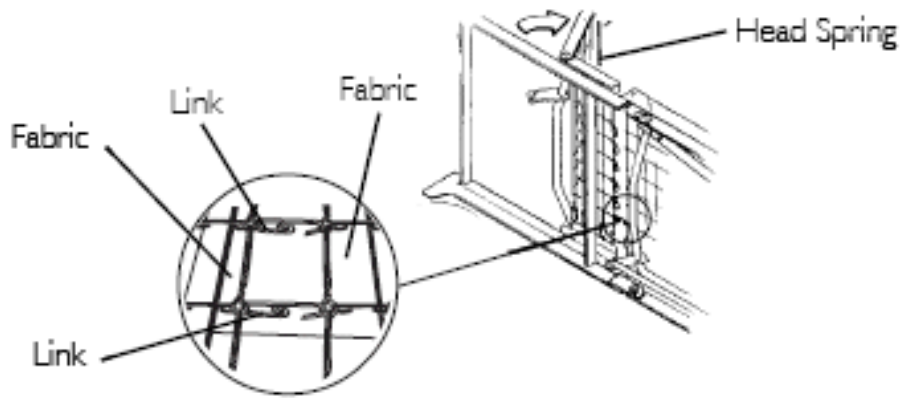

Head Section Pull Tube

Connect the loose pull tube end assembly (attached to the motor) to the lift arm of the head spring using the clevis pin. This piece allows the head raising feature.

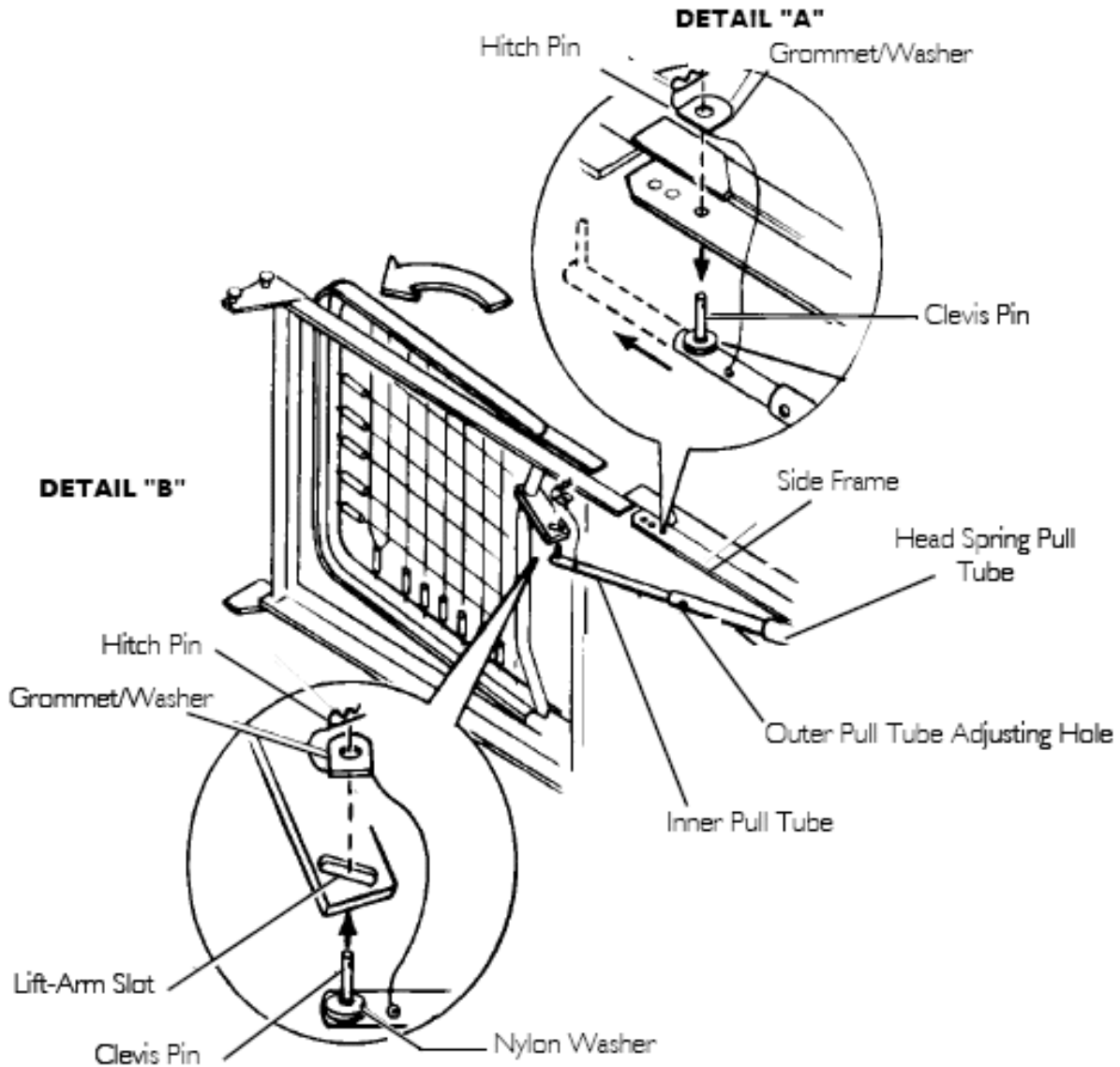

Head & Footboards

The head and footboard pieces may be referred to as universal bed ends, and depending on the brand and model of your hospital bed, the headboard may be the same as the footboard, but not always. Some bed ends have an extended output shaft, others have a 'flush' shaft. Some fully electric models will have a spring-loaded coupler shaft on the headboard.

To assemble;

- Stand one bed end as close to the head spring section as possible, with the corner locks facing the bed.
- Each person should grasp one end of the head spring section, on the side, with the other hand holding the top of the bed end. Raise the bed until the rivets on the corner plates of the spring section are high enough to place into the corner locks on the bed end.
- It may be easier to tilt the bed end toward the head spring section to place the rivets into the corner locks.
- Return the universal bed end to its full upright position. The head spring rivets will lock into place.
- Repeat the same procedure for other bed end.

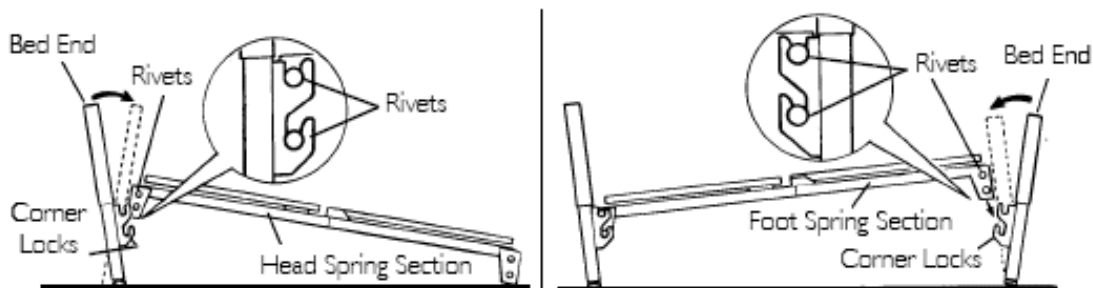

Notice at the foot-end of the bed (the end with the motor assembly), the footboard may have a gear box with a spring-loaded coupler in the center where the drive motor engages the footboard. (this is on fully-electric beds only) This must be connected so that the drive-shaft from the motor matches up with the receiver in the footboard. This drive rod is spring-loaded. It should be compressed and released into the footboard to engage. The photo marked Detail "A" shows the engaged unit. The first photo on the next page shows how to engage it.

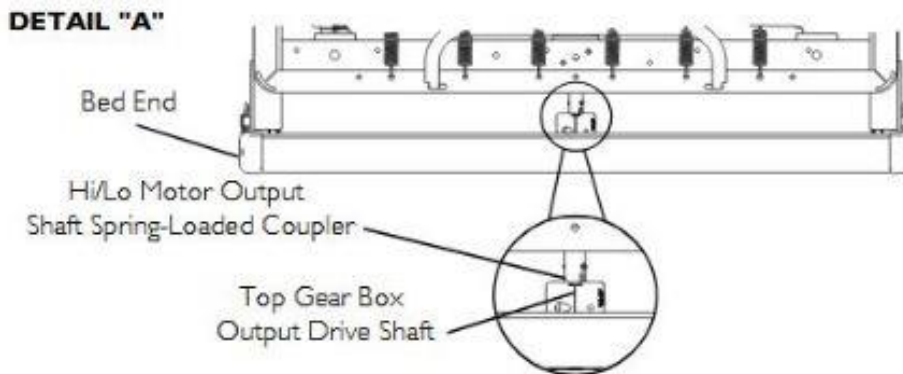

In semi-electric beds, some bed ends have an extended output shaft, others have a 'flush' shaft. If the gear box has two options for shafts, one will be marked as FOOT END, the other for HEAD END, with a plastic cover. This universal bed end allows you to assemble the bed, then choose the correct output.

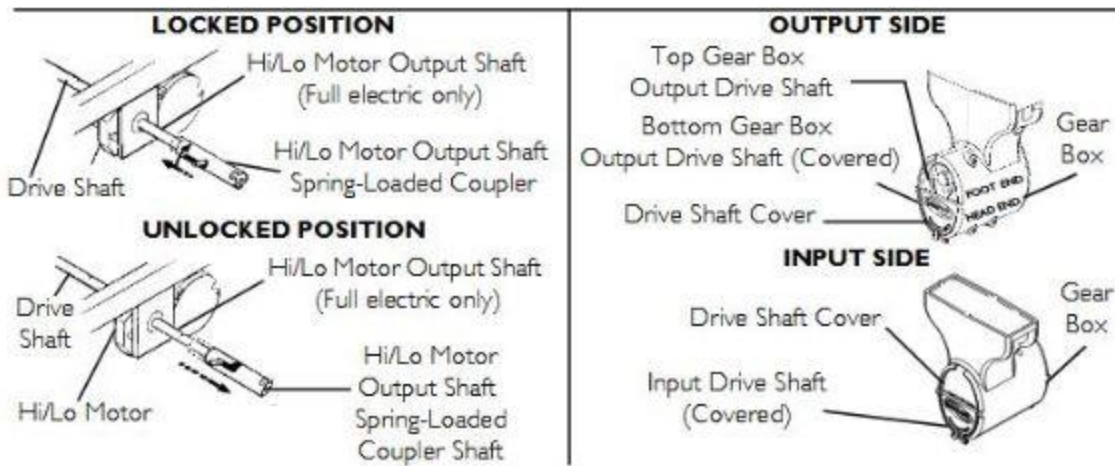

FIGURE 4.10 Assembling the Drive Shaft

Attaching the Hi/Low Drive-Shaft (long squared tube)

The high/low drive-shaft raises/lowers the entire bed for both the fully electric and the semi-electric design. This long spring-loaded rod connects from the motor, located at the foot-end of the bed, to the receiver built into the headboard (for fully-electric), or connects both the headboard and footboard (for semi-electric). This drive-rod is spring loaded and must be slightly compressed and released to secure to the drive shaft. Before beginning, make sure that the drive shaft is extended to the proper length, as they are universal. To do this, you may have to depress the rounded button and pull/push the shaft.

Although it does not matter which end you connect first, (for proper functioning of the bed), we have found that it is easier to do it this way;

- Using with the non spring-loaded end, insert the drive shaft into the motor (for fully electric) or the footboard (for semi-electric). Make sure the drive shaft is above the metal cross brace of the lower bed.
- Lifting the head spring section out of the way, step into the bed frame. Pull back on the spring-loaded end to insert it into the drive shaft. You may need to twist it to 'catch' the cross bar.

*The drive shaft is adjustable and may need to be adjusted to engage properly.

**The receivers on most head/foot boards allow them to be universal. They are marked as such. Please make sure you have attached the drive shaft into the correct receiver.

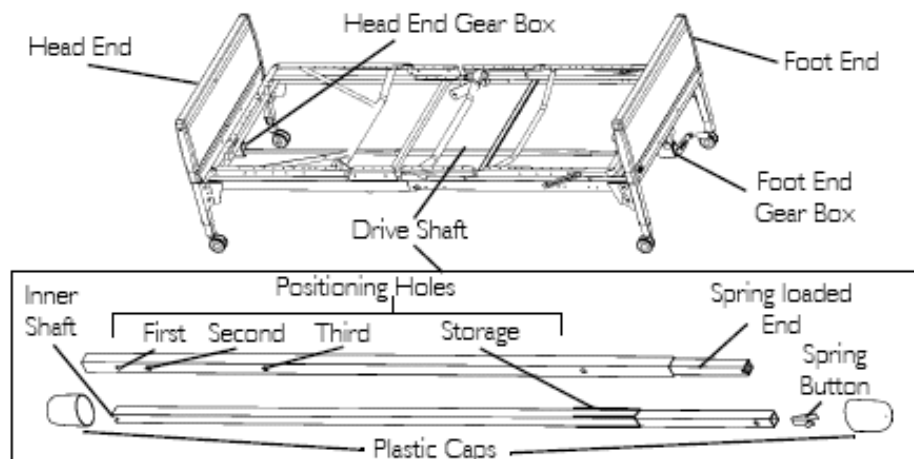

For reference: The bed can be locked once it is rolled into place.

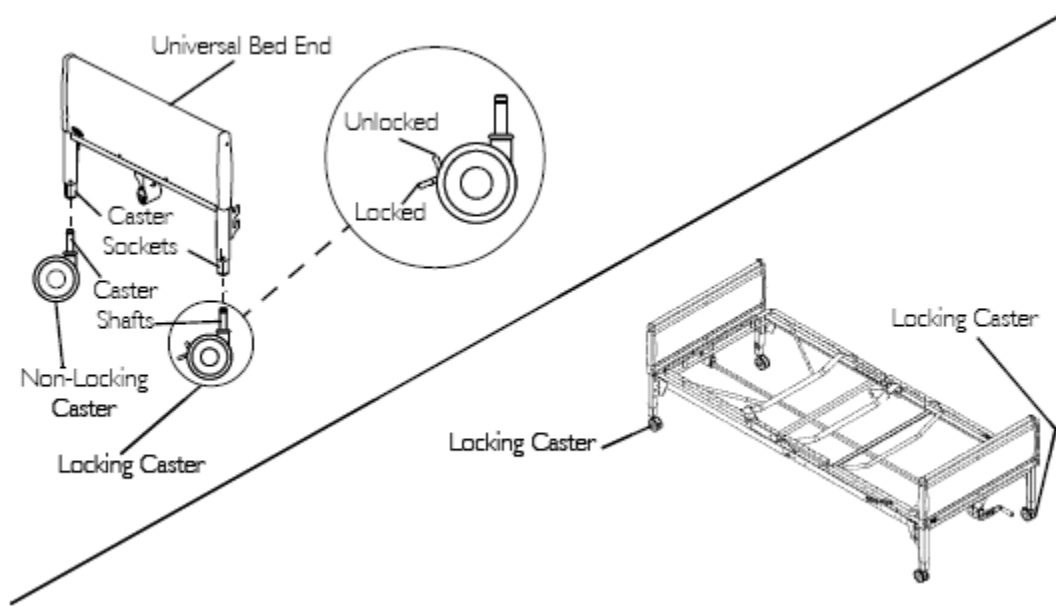

Testing

Plug-in the bed and try each individual control button on the hand pendant. If one of the functions is not working properly, troubleshooting is straightforward. If not, check the plug-in connection to the motor.

The foot-end raise/lower function is usually the least troublesome since it is already pre-assembled.

The head-end raise/lower function will perform properly if the "head spring pull tube" is connected properly. If not, check the plug-in connection to the motor.

The bed hi/low function is usually where self-installers have a problem since the drive shaft/rod must connect properly into the footboard. If the bed won't raise/lower correctly, check the drive rod connections and make sure the center of the shafts are locked into the rod and not just free-spinning. If the head end of the bed is raising/lowering, but the foot end is not, (or vice versa) you will need to inspect the connection at the gear box, making sure they are properly inserted.

Below are a couple of photos showing the connections between the drive shaft (and on fully-electric models, the motor) and the head and foot board.



13. Release the spring loaded shaft on the hi/low motor and insert the shaft into the gear box on the footboard.



14. Make sure the slot on the spring loaded shaft engages the roll pin on the gear box.